

FULLY HYDRAULIC COMPACT EXCAVATOR | **TB235**

| **TB235**

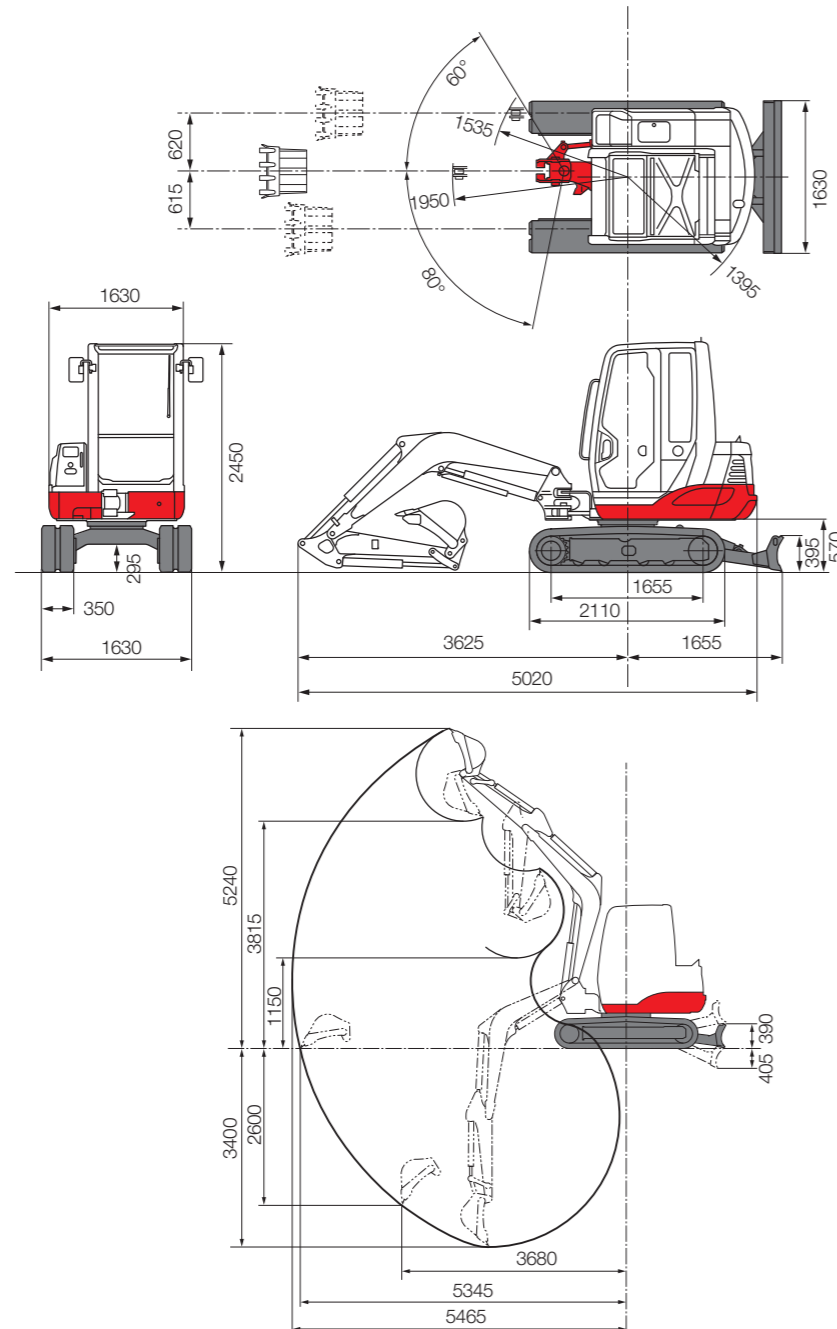

**TB235**

Standard UK Specification - Long Dipper/Rubber Tracks

Engine	
Make	Yanmar
Model	3TNV88
Rated Output (kW/rpm)	21.5/2400
Maximum Torque (Nm)	98.6-107.4
Cylinders	4
Displacement (cc)	1642
Electrical System	12volts 40amp

Dimensions & Weight	
Operating Weight inclusive of bucket and fuel (kg)	3580
Overall Length (mm) for transport	5020
Width (mm)	1630
Height (mm)	2450
Ground Clearance (mm)	295
Min. Front Swing Radius (mm)	1535
Slew Radius (mm)	1395
Dozer Blade (W x H) (mm)	1630 x 395

Operating Information	
Max Digging Depth (mm)	3400
Max Dump Height (mm)	3815
Max Reach at Ground Level (mm)	5345
Max Reach at Vertical Digging Depth (mm)	3680
Max Bucket Digging Force (kN)	27
Max Arm Digging Force (kN)	16.0

Hydraulic System	
Set Pressure (bar)	210
Pump Type	Variable x 2 +Gear x 2
Hydraulic Flow (l/min)	38.9x2+22.8x1+10.8x1
Auxiliary Flow Port 1,2,3 (l/min)	61.7,22.8,10.8

Swing System	
Boom Swing Angle (L/R)	80°/60°
Slew Speed (rpm)	10
Slew Motor	Piston
Slew Brake	Disc

Undercarriage	
Traction Motor	Axial Piston
Traction Drive	Planetary
Traction Brake	Disc
Track Width (mm)	350
Ground Contact Length (mm)	2110
Ground Pressure (kpa)	27.9
Travel Speed (K/ph)	2.6/5
Maximum Gradeability	30°

Capacities	
Hydraulic System (l)	35
Fuel Tank (l)	53
Engine Lubrication (l)	4.7
Cooling System (l)	8.7

All dimensions unless otherwise stated are in millimetres



For more information locally  
call us direct, or contact:

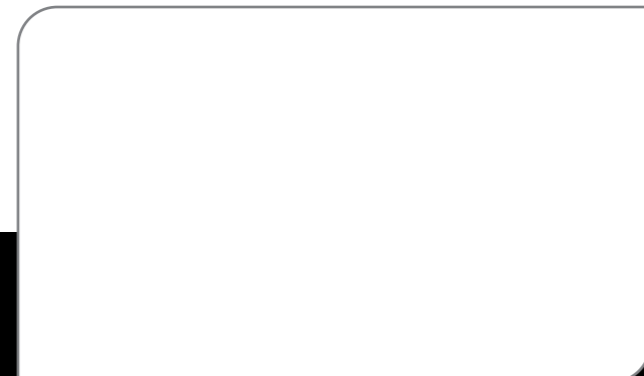

Takeuchi Mfg (UK) Ltd, Lynroyle Way, Rochdale, Lancashire OL11 3EX  
Tel: 01706 657 722 Fax: 01706 657 744

Southern Depot at 20 Colthrop Business Park  
Colthrop Lane, Thatcham, Newbury, Berks RG19 4NB  
Tel: 01635 877 196 Fax: 01635 877 195

www.takeuchi-mfg.co.uk Email: sales@takeuchi-mfg.co.uk

**TAKEUCHI**  
Japanese for reliability

FULLY HYDRAULIC  
**MINI**  
EXCAVATOR

**TAKEUCHI**  
Japanese for reliability

\*Warranty exceptions to 1 year: fuel injections systems, electrical components, paint work.  
In accordance with our established policy of constant improvement, we reserve the right to amend these specifications at any time without notice.  
Photographs shown may feature non-standard equipment.

**TAKEUCHI**FULLY HYDRAULIC MINI EXCAVATOR | **TB235**

## TB235 Mini Excavator - powerful performance

Introducing the new styled Takeuchi 3.6 tonne mini excavator. Weighing in at 3580kg, the new TB235 is packed full of performance. Designed to give operators even more comfort and operating ability, the new styled Takeuchi has a roomy cab, comfortable adjustable seating and better positioned controls.

The TB235 is designed for tough digging performance and powerful breakout force. The new TB235 performs with 3.6 tonne force to operate comfortably in the toughest working conditions.

The TB235 is powered by a 21.5kW/2400rpm Yanmar 3TNV88 engine, 3 tier specification meets all the latest emission and noise requirements essential for on-site health and safety.

### NEW STYLED CAB WITH IMPROVED VISIBILITY

The distinctive styled cab provides a comfortable working environment. The front window easily retracts into the roof, making operators more comfortable. TB235 operators have the advantage of improved 360° visibility.



### ADDED GRADEABILITY WITH IMPROVED DOZER BLADE

The new styled dozer blade makes all the difference when grading. With added height and greater curve the new dozer blade reduces overflow of material and adds to a good finished area.



### OPERATOR COMFORT

With adjustable arm rests and seat, along with air conditioning options, the new TB235 is a comfortable alternative. With MP3 socket and drinks holder, operators can work in comfort. Additional foot-room and a larger cab make for a roomier working environment.

### DESIGNED FOR SERVICE

Service and maintenance are a priority across all the Takeuchi range. The TB235 features the unique tilt-up cab. Excellent service access points, allow for regular simple service schedules to be performed easily.



### PERFORMANCE

- Two speed tracking and simultaneous cab swing and dig functions all add up to faster working speeds for the TB235.
- Short pitch rubber tracks add to performance with far less potential for ground damage.
- Emergency shut-off valve - if the boom cylinder hose for lifting is ruptured, the emergency shut-off valve is activated to prevent the boom from falling rapidly.
- Overload warning device - if a weight greater than the lifting capacity is applied or lifted, the overload warning device is activated and the horn sounds.

### OPERATION

- A comfortable cab incorporates useful operating features;
- Pilot operated joystick controls and foot pedals makes for easy uncomplicated drive and operation.
  - Adjustable seat and arm rests.
  - Two way auxiliary hydraulics plumbed to the boom arm allows alternative tools to be used on site.

### SAFETY & SERVICE

- Electronic engine monitoring.
- Automatic fuel bleed system.
- Remote slew lubrication system.
- Vandalism protected lockable fuel tank and engine compartment.
- Hydraulic oil cooler.
- Engine oil Safe Drain system.
- All Takeuchi machines come with a 2 year/2000 hrs warranty as standard (\*exceptions apply)
- Option - Accumulator assists the residual pressure in the auxiliary circuit, so hydraulic tools can be released even after the engine is stopped.
- Option - Double Element air filters for cleaner air into the engine.

### OPTIONS

- Air conditioning
- QuickHitch
- TKB101 Hydraulic Breaker
- Auger
- Steel tracks

Takeuchi mini excavators are best known for reliable and touch sensitive hydraulics. The light touch gives the operators a powerful machine, without operators taking the impact - the roomy isolated cab minimises the impact to the operators.

Added counter weights positioned central to the machine massively assist with balance and tip-up action. For a 3.6 tonne mini the TB235 offers excellent dig depth to 3400mm and ground level reach of 5345mm.

Higher than average bucket breakout force of 27kN, gets a big dig performance in a compact 3.6 tonne mini excavator, powerful enough for the toughest ground conditions.

If you're familiar with Takeuchi mini excavators in your fleet, the new TB235 offers many well proven features now in a new styled and comfortable cab.

So if you're looking for a powerful high performance 3.6 tonne mini the new Takeuchi TB235 is built for the job.

**With a reputation for reliability, Japanese build quality makes all the difference.**

